

Automation
systems for sliding
gates weighing
up to 2200 kg



BK

**Total automation
flexibility for multi-user
access ways**

BK is the ideal solution when automating condominium and industrial facility access ways. Its complete range features 9 versions designed to meet the gate's duty and weight requirements.



CAME
AUTOMATIC GATES

BK

230V 400V three-phase

Functionality,
innovation,
versatility and
safety

BK provides the complete solution when gate automation is required in condominium, industrial and collective access ways in general. The product range includes a good 9 versions to meet all and any applicative requirements. This includes a three-phase powered model for industrial facilities. BK stands for cutting-edge technology when it comes to duty and safety, as required by CAME standards.



Designed to withstand anything

DO AWAY
with laborious
release
procedures

Exclusively practical. BK-1200P features the PRATICO SYSTEM, an extremely user-friendly CAME patented device which replaces the laborious, manual release procedures required during a power outage, and does away with the hassle of searching for the keys.

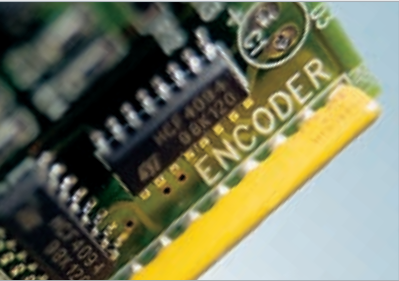

Encoder technology. A safe, constant, electronically controlled motion, providing maximum assurance and safety for those using the gate.



A safe system. In all of the versions, the control electronics are built-into the unit (except for version BK2200T) and is protected from environmental agents.

Total auto-control. Prior to opening or closing the gate, the built-in electronics tests the proper functioning of all the safety devices hooked up to the system.

Easier and safer operations. BK can be connected to and control any auxiliary lighting, which turns on each time the gate opens, making it easier and safer to drive in and out.



Designed to last. Carefully chosen materials give BK sturdiness and lasting power, to withstand heavy-duty use.

Safety and careful attention to detail. The INTEGRATED mounting and adjustment system for the gearmotor is located inside the automation device. This makes it even safer when floor mounting the unit.



The 230V electronics

Besides the normal command and safety functions, the new electronics found in the 230V BK series provides certain features that enables total control and optimal duty performance to be obtained. Here are some examples:

- > **Safe and simplified access**
with the option of connecting and controlling the auxiliary lighting for the access area.
- > **Partial opening**
to favour pedestrian access, without having to open the gate entirely.
- > **System's active safety-devices test**
performed prior to each gate opening and closing.

Advantages of the Three-phase BK

When total power, performance and reliability are needed, the BK three-phase technology enables the automation device to reach its full potential, meaning:

- > **Increased thrust when in operation**
The 230-400V three-phase electronics provides additional dynamic traction during the initial stage of the opening/closing phases, thus addressing any issues concerning the weight of the gate.
- > **Frequent accesses**
The three-phase gearmotor ensures functioning even under the most severe conditions of use, such as in industrial facilities.
- > **Inertia control**
The weight of large gates used at industrial facilities is often an issue. The considerable mass of the gate generates passive inertia at the end of the opening/closing phases. BK 2200T, featuring the new ZT6 control panel, can control the effects of passive inertia, making access safer.



Standard installation:

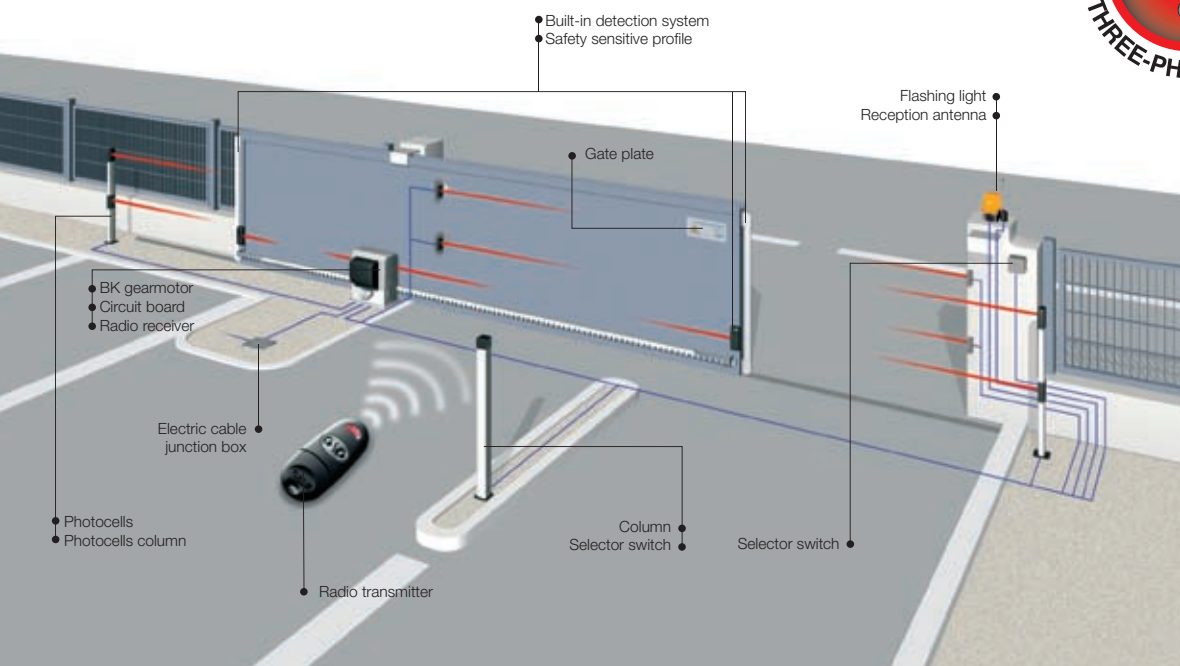

In the event a careful analysis of the automated gate's risks were to require it, the use of sensitive safety infrared or contact profiles becomes indispensable.



The models

230V Gearmotors

- BK-800** Complete 230V A.C. automation device for sliding gates weighing up to 800 kg, and with MODULE 4 pinion
- BK-1200** Complete 230V A.C. automation device for sliding gates weighing up to 1200 kg, and with MODULE 4 pinion
- BK-1200P** Complete 230V A.C. automation device for sliding gates weighing up to 1200 kg, and with MODULE 4 pinion, built-in PRATICO SYSTEM radio release system and 12V - 1.2Ah incorporated emergency battery
- BK-1800** Complete 230V A.C. automation device for sliding gates weighing up to 1800 kg, and with MODULE 4 pinion
- BK-2200** Complete 230V A.C. automation device for sliding gates weighing up to 2200 kg, and with MODULE 6 pinion

- BKE-1200** Complete 230V A.C. automation device with ENCODER for sliding gates weighing up to 1200 Kg, and with MODULE 4 pinion
- BKE-1800** Complete 230V A.C. automation device with ENCODER for sliding gates weighing up to 1800 Kg, and with MODULE 4 pinion
- BKE-2200** Complete 230V A.C. automation device with ENCODER for sliding gates weighing up to 2200 Kg, and with MODULE 6 pinion

230-400V Three-phase gearmotors

- BK-2200T** 230-400V Automation device without circuit board for sliding gates weighing up to 2200 kg, and with MODULE 6 pinion

230-400V Three-phase control panel

- ZT6** 230-400V three-phase control panel with built-in radio decoder and auto-diagnosis of safety devices

PRODUCTS



Made in Italy



For its quality processes management Came Cancelli Automatici is ISO 9001:2000 certified, and for its environmental management it is ISO 14001 certified. Came designs and manufactures entirely in Italy.

Technical features:

Type	BK-800	BK-1200/E	BK-1200P	BK-1800/E	BK-2200/E	BK-2200T
Degree of protection	IP54					
Control board power supply (50/60Hz)	230V A.C.					230-400V A.C.
Motor power supply (50/60Hz)	230V A.C.					230-400V A.C.
Absorbed input	4,5A	3,3A	3,3A	4,2A	5,1A	1,5A
Max power	520W	380W	380W	480W	580W	600W
Speed	10,5 m/min		14,5 m/min		10,5 m/min	
Operation intermittence	intensive use 50%		30%		30%	
Traction force	800N	850N	850N	1150N	1500N	1650N
Operating temperature	-20°C ÷ +55°C					

Limits to use:

Series	BK-800	BK-1200/E	BK-1200P	BK-1800/E	BK-2200/E	BK-2200T
Max weight of gate leaf (Kg)	800	1200	1200	1800	2200	2200
Max length of gate leaf (m)	13					

Dimensions:

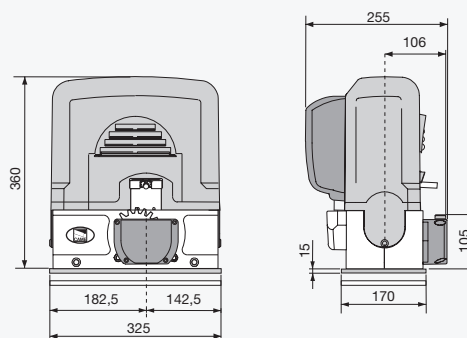

Came
cancelli automatici
s.p.a.

via Martiri della Libertà, 15
31030 Dosson di Casier
Treviso - Italy

www.came.it - info@came.it